

Combined Lightning Current and Surge Arrester

ProTec ZPS T1H 3+0(-R)-L

Class I • Class II • Type 1 • Type 2



Location of Use: Main Distribution Boards,
40mm Busbar Systems

Network Systems: TN-C

Mode of Protection: L-PEN

IEC/EN: Class I+II / Type 1+2

Technology: Hybrid

Leakage Current Free: Yes

Line Follow Current: No

Housing: Compact design

Compliance: IEC 61643-11:2011
EN 61643-11:2012

Technical Data

ProTec ZPS T1H-xxx-3+0(-R)-L

IEC Electrical

Nominal AC Voltage (50/60Hz)	U_o/U_n	240 V
Maximum Continuous Operating Voltage (AC)	U_c	300 V
Nominal Discharge Current (8/20 μ s)	I_n	20 kA
Maximum Discharge Current (8/20 μ s)	I_{max}	50 kA
Impulse Discharge Current (10/350 μ s)	I_{imp}	12.5 kA
Specific Energy	W/R	39 kJ/ Ω
Charge	Q	6.25As
Voltage Protection Level	U_p	1500V
Response Time	t_A	< 100ns
Overcurrent Protection (max)		315 A gG
Short-Circuit Current Rating (AC)	I_{SCCR}	25 kA
TOV Withstand 120min	U_T	442 V
Number of Ports		1

Mechanical & Environmental

Operating Temperature Range	T_a	-40 °F to +185 °F [-40 °C to +85 °C]
Permissible Operating Humidity	RH	5%...95%
Altitude (max)		13123 ft [4000m]
Terminal Screw Torque	M_{max}	PZ2 / 39.9 lbf-in [4.5Nm]
Conductor Cross Section (max)		35 mm ² (Solid, Stranded) / 25 mm ² (Flexible) 2 AWG (Solid, Stranded) / 4 AWG (Flexible)
Mounting		40mm Busbar Systems
Degree Of Protection		IP 20*
Housing Material		Thermoplastic: Extinguishing Degree UL 94 V-0
Operating State / Fault Indication		Green Flag / Not Green Flag
Remote Contacts (RC)		Optional
RC Switching Capacity		AC: 250V/ 1A, 125V/ 1A; DC: 48V/0.5A, 24V/0.5A, 12V/0.5A
RC Conductor Cross Section (max)		1.5mm ² (Solid) / 16 AWG (Solid)

Load Terminal (L1')

Rated Current	I_L	20A
Load Side Overcurrent Protective Device		20A gG
Wire Connection Method		Push In
Conductor Cross Section		10 AWG / 4 mm ² (Solid, Stranded, Flexible)
Stripping Length		16 mm

Order Information

Order Code		
ProTec ZPS T1H-300-3+0-L (with load terminal)		59.0902
ProTec ZPS T1H-300-3+0-R-L (with remote contacts and load terminal)		59.0903

*IP 40 (in combination with cover)

ProTec ZPS T1H 3+0(-R)-L

Internal Configuration

Legend

- L Line Busbar Terminal
- L1' Load Terminal
- PEN PEN Busbar Terminal
- ⏏ Terminal for Main Earthing Terminal
- RC Remote Contacts Terminal (Optional)
- TD Thermal Disconnect

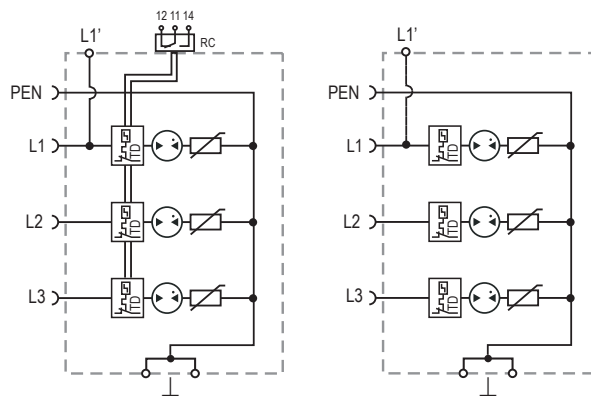

Complete Unit

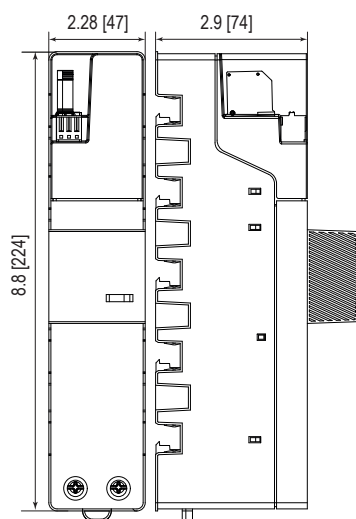

Complete Unit Dimensions & Packaging

ProTec ZPS T1H-xxx-3+0-L	300
Weight pounds [grams]	1.570 [712]
Packaging Dimensions (HxWxL)	12.5 x 13.4 x 9.5" [320 x 340 x 240 mm]
Standard Order Quantity	18 Units
ProTec ZPS T1H-xxx-3+0-R-L	300
Weight pounds [grams]	1.587 [720]
Packaging Dimensions (HxWxL)	12.5 x 13.4 x 9.5" [320 x 340 x 240 mm]
Standard Order Quantity	18 Units

inches
[mm]

Information contained in this document is subject to change at any time without notice.

