

Pluggable Multi-Pole SPD for Photovoltaic Systems

ProTec T2-PV 3+0

Class II • Type 2



Location of Use: String box, Inverter
 Mode of Protection: (+)-PE, (-)-PE, (+)-(-)
 Surge Ratings: $I_n = 20\text{ kA (8/20 }\mu\text{s)}$
 $I_{\text{Total}} = 50\text{ kA (8/20 }\mu\text{s)}$
 IEC/EN Category: Class II/Type 2
 Housing: Pluggable Design
 Compliance: IEC 61643-31:2018
 EN 61643-31:2019

Technical Data

ProTec T2-xxxPV-3+0(-R)	250	600	
EN Electrical			
Maximum Continuous Operating DC Voltage	U_{CPV}	250 V	600 V
Nominal Discharge Current (8/20 μs)	I_n	20 kA	20 kA
Maximum Discharge Current (8/20 μs)	I_{max}	50 kA	50 kA
Total Discharge Current	I_{Total}	50 kA	50 kA
Voltage Protection Level (8/20 μs)	U_p	1000 V	2000 V
Response Time	t_A	< 25 ns	
Short-Circuit Current Rating	I_{SCPV}	11 kA	
Number of Ports		1	
Mechanical & Environmental			
Operating Temperature Range	T_a	-40 °F to +185 °F [-40 °C to +85 °C]	
Permissible Operating Humidity	RH	5%...95%	
Altitude (max)		13123 ft [4000 m]	
Terminal Screw Torque	M_{max}	40 lbf-in [4.5 Nm]	
Conductor Cross Section (max)		2 AWG (Solid, Stranded) / 4 AWG (Flexible) 35 mm ² (Solid, Stranded) / 25 mm ² (Flexible)	
Mounting		35 mm DIN Rail, EN 60715	
Degree of Protection		IP 20 (built-in)	
Housing Material		Thermoplastic: Extinguishing Degree UL 94 V-0	
Thermal Protection		Yes	
Operating State / Fault Indication		Green Flag / Not Green Flag	
Remote Contacts (RC)		Optional	
RC Switching Capacity		AC: 250V/1A, 125V/1A; DC: 48V/0.5A, 24V/0.5A, 12V/0.5A	
RC Conductor Cross Section (max)		16 AWG (Solid) / 1.5 mm ² (Solid)	
Order Information			
Order Code	250	600	
ProTec T2-xxxPV-3+0	59.0985	59.0986	
ProTec T2-xxxPV-3+0-R (with remote contacts)	59.0979	59.0980	
ProTec T2-125PV-P	59.A300	-	
ProTec T2-300PV-P	-	59.0992	

ProTec T2-PV 3+0

Internal Configuration

Legend

- +/-, -/+ Terminal for +/-, -/+ Conductor
- ⊥ Terminal for PE/G Conductor
- RC Remote Contacts Optional
- TD Thermal Disconnect

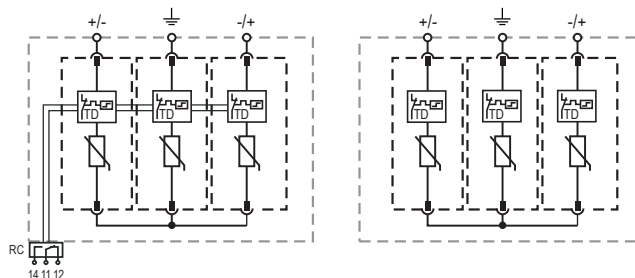

Complete Unit

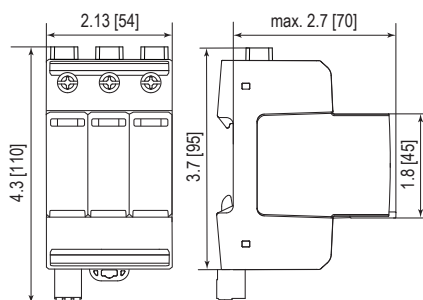

Dimensions & Packaging

		250	600
Single Unit Weight	pounds	.696	.745
	grams	316	338
		250	600
Single Unit Weight	pounds	.509	.753
	grams	321	342
Single Unit DIN 43880 Dimension		3 TE / 2.13 [54]	
Packaging Dimensions (HxWxL)		4.3 x 4.5 x 13.8" [109 x 115 x 352 mm]	
Standard Order Quantity		5 Units	

Plug Internal Configuration

ProTec T2-xxxPV-P

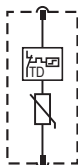

Spare Plug

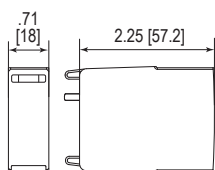

Dimensions & Packaging

		125	300
Single Unit Weight	pounds	.110	.121
	grams	50	55
Single Unit DIN 43880 Dimension		1 TE / .71 [18]	
Packaging Dimensions (HxWxL)		3.2 x 4.5 x 12" [83 x 115 x 305 mm]	
Standard Order Quantity		24 Units	

inches
[mm]

Information contained in this document is subject to change at any time without notice.

