

**DATA SHEET**

## Single-pole PCB Mount SPD Socket for PV System

**PCB Socket T1 PV(-R)**

Class I • Class II • Type 1 • Type 2 • Type 1CA



Location of Use: String box, Inverter  
 Mode of Protection: (+)-PE, (-)-PE, (+)-(-)  
 IEC/EN/UL Category: Class I+II, Type 1+2 / Type 1CA  
 Housing: PCB Mount  
 Compliance: IEC 61643-31:2018  
 EN 61643-31:2019  
 UL 1449 5th Edition

**Technical Data****PCB Socket T1 PV(-R)****EN Electrical**

Maximum Continuous Operating Voltage (PV)	$U_{OPV}$	up to 750V
Nominal Discharge Current (8/20 $\mu$ s)	$I_n$	up to 20kA
Impulse Discharge Current (10/350 $\mu$ s)	$I_{imp}$	up to 6.25kA
Specific Energy	W/R	up to 9.77 kJ/ $\Omega$
Charge	Q	up to 3.125As
Maximum Discharge Current (8/20 $\mu$ s)	$I_{max}$	up to 40kA
Total Discharge Current (10/350 $\mu$ s)	$I_{Total}$	up to 12.5kA
Short-Circuit Current Rating	$I_{SCPV}$	up to 30kA
Number of Ports		1

**UL Electrical**

Maximum Permitted DC Voltage	$V_{pVdc}$	up to 750V
Nominal Discharge Current (8/20 $\mu$ s)	$I_n$	up to 20kA
Short-Circuit Current Rating	SCCR	up to 65kA

**Mechanical & Environmental**

Operating Temperature Range	$T_a$	-40 °F to +185 °F [-40 °C to +85 °C]
Permissible Operating Humidity	RH	5%...95%
Altitude (max)		13123 ft [4000m]
Mounting		Printed Circuit Board (PCB)
Degree Of Protection		IP 20 (built-in PCB, with protection module plugged in)
Housing Material		Thermoplastic: Extinguishing Degree UL 94 V-0
Remote Contacts (RC)		Optional
RC Switching Capacity		AC: 250V/1A, 125V/1A; DC: 48V/0.5A, 24V/0.5A, 12V/0.5A

\*Product with T2 sized locking clip.

For complete line of Raycap product solutions or dedicated case applications please contact us: [info@raycap.com](mailto:info@raycap.com).

## Installation Configuration

## PCB Socket T1 PV(-R)

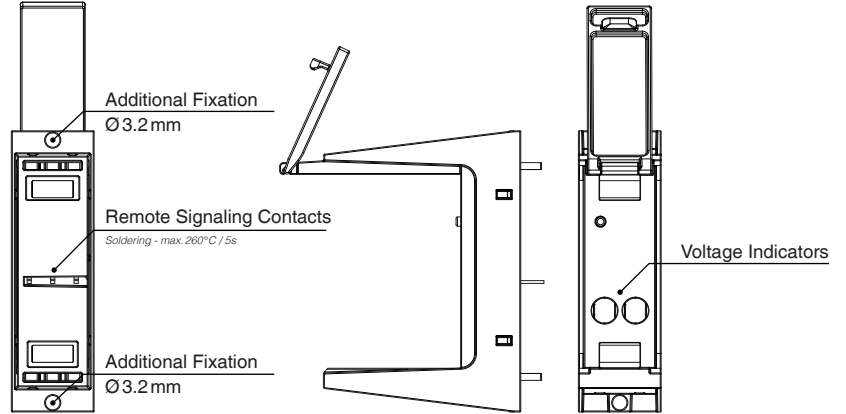

## Complete Unit

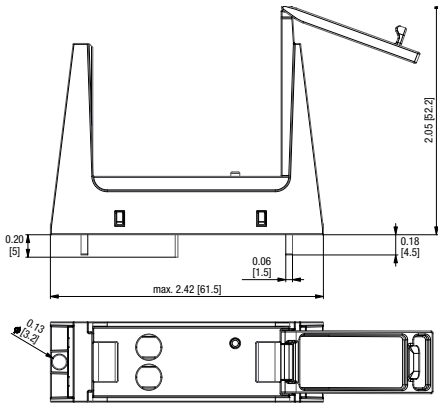

### Single Unit Dimensions & Packaging

#### PCB Socket T1 PV

Weight	pounds	.046
	grams	21 g

#### PCB Socket T1 PV-R

Weight	pounds	.048
	grams	22 g

DIN 43880 Dimension 1 TE / .71" [18]

Packaging Dimensions (H x W x L) 14.8 x 2.5 x 2.6" [377 x 64 x 67 mm]

Standard Order Quantity 20 Units

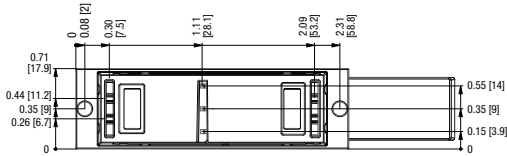

inches  
[mm]

Information contained in this document is subject to change at any time without notice.

