

DATASHEET

Compact SPD for Motorized Window Shades

ProTec BLD T2-275(-01)

Class II • Type 2 • Class III • Type 3

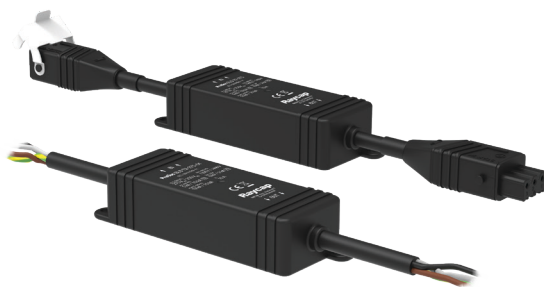

Location of Use: Motorized Window Shades
 Network Systems: TN-S, TT
 Mode of Protection: L-N, N-PE
 IEC/EN Category: Class II+III / Type 2+3
 Housing: Compact Design
 Compliance: IEC 61643-11:2011
 EN 61643-11:2012+A11:2018

Technical Data

ProTec BLD T2-275(-01)

275

Electrical

Nominal AC Voltage (50/60 Hz)	U_o	230V
Maximum Continuous Operating Voltage (AC)	(L-N) U_c	275V
	(N-PE) U_c	255V
Nominal Discharge Current (8/20 μ s)	(L-N)/(N-PE) I_n	5kA/10kA
Maximum Discharge Current (8/20 μ s)	(L-N)/(N-PE) I_{max}	10kA/10kA
Open Circuit Voltage of the Combination Wave Generator (1.2/50 μ s)	(L-N)/(N-PE) U_{oc}	6kV/6kV
Short-Circuit Current of the Combination Wave Generator (8/20 μ s)	(L-N)/(N-PE) I_{cw}	3kA/3kA
Total Discharge Current (8/20 μ s)	I_{Total}	15kA
Voltage Protection Level	(L-N)/(N-PE) U_p	1.3kV/1.4kV
Follow Current Interrupt Rating	(N-PE) I_{fi}	100A
Maximum Load Current	I_L	10A
Response Time	(L-N)/(N-PE) t_A	< 25 ns / < 100 ns
Overcurrent Protection (max)	(L-N)	MCB/B 10A
Short-Circuit Current Rating (AC)	I_{SCCR}	1.5kA
TOV Withstand 5s	(L-N) U_T	335V
TOV Safe Fail 120min	(L-N) U_T	442V
TOV Withstand 200ms	(N-PE) U_T	1200V/300A
Number of Ports		1

Mechanical & Environmental

Temperature Range	T_a	-40 °F to +185 °F [-40 °C to +85 °C]
Permissible Humidity	RH	5%...95%
Altitude		13123 ft [4000 m]
Pollution Degree		2
Connector		Hirschmann STAK 3/STAS 3
Degree of Protection		IP 54
Housing Material		Thermoplastic: Extinguishing Degree UL 94 V-0
Thermal Protection		Yes
Fault Indication		Acoustic Fault Indication

Internal Configuration

Legend

- L Line Conductor
- N Neutral Conductor
- ⏏ PE Conductor Terminal
- TD Thermal Disconnect Fuse

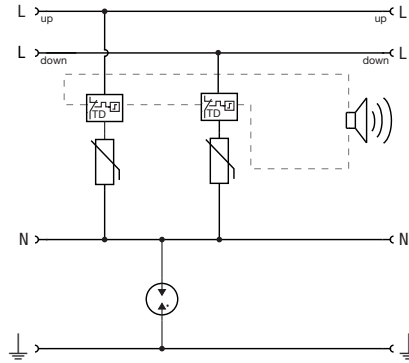

ProTec BLD T2-275(-01)

Order Information

Order Code	
ProTec BLD T2-275 (with connectors)	515 644
ProTec BLD T2-275-01 (without connectors)	515 A32

Dimensions & Packaging

inches [mm]

Complete Unit	
ProTec BLD T2-275	275
Single Unit Weight	.441 [200g]
ProTec BLD T2-275-01	
Single Unit Weight	.265 [120g]
Packaging Dimensions (H x W x L)	1.8 x 2 x 13.2" [30 x 50 x 335mm]
Minimum Order Quantity	1 Unit

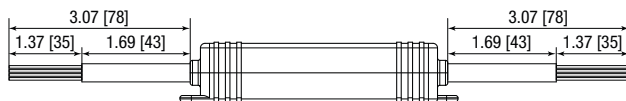
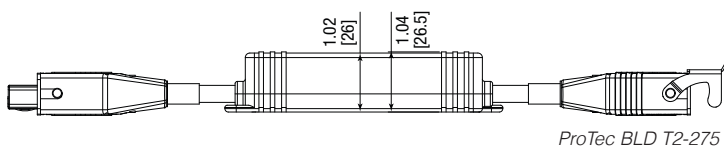
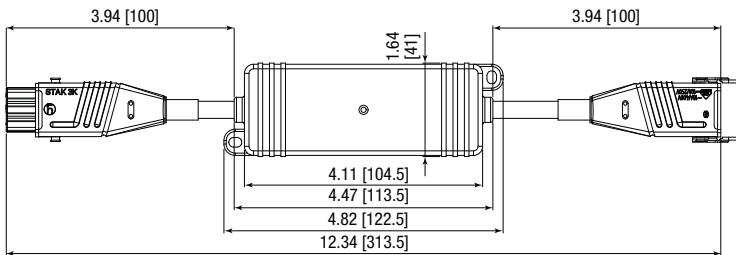

ProTec BLD T2-275-01

Information contained in this document is subject to change at any time without notice.

