

Combined Lightning Current and Surge Arrester

ProTec 60 T2 3+0

Class II • Type 2



Location of Use: Main Distribution Boards,
60 mm Busbar Systems

Network Systems: TN-C

Mode of Protection: L-PEN

IEC/EN: Class II / Type 2

Housing: Pluggable design

Compliance: IEC 61643-11:2011
EN 61643-11:2012 + A11:2018

Technical Data

ProTec 60 T2-xxx-3+0(-R)

300

IEC Electrical

Nominal AC Voltage (50/60Hz)	U_o / U_n	240 V
Maximum Continuous Operating Voltage (AC)	U_c	300 V
Nominal Discharge Current (8/20 μ s)	I_n	20 kA
Maximum Discharge Current (8/20 μ s)	I_{max}	50 kA
Voltage Protection Level	U_p	1500 V
Response Time	t_A	< 25 ns
Overcurrent Protection (max)		160 A gG
Short-Circuit Current Rating (AC)	I_{SCCR}	25 kA
TOV Withstand 5s	U_T	337 V
TOV Safe Fail 120min	U_T	442 V
Number of Ports		1

Mechanical & Environmental

Operating Temperature Range	T_a	-40 °F to +185 °F [-40 °C to +85 °C]
Permissible Operating Humidity	RH	5%...95%
Altitude (max)		13123 ft [4000m]
Terminal Screw Torque	M_{max}	PH2 / 40 lbf-in [4.5Nm]
Conductor Cross Section (max)		2 AWG (Solid, Stranded) / 4 AWG (Flexible) 35 mm ² (Solid, Stranded) / 25 mm ² (Flexible)
Mounting		60 mm Busbar Systems Width: 12, 15, 20, 25, 30 mm Thickness: 5 mm, 10 mm (with removed spacers)
Degree Of Protection		IP 20*
Housing Material		Thermoplastic: Extinguishing Degree UL 94 V-0
Operating State / Fault Indication		Green Flag / Not Green Flag
Remote Contacts (RC)		Optional
RC Switching Capacity		AC: 250V/1 A, 125V/1 A; DC: 48V/0.5 A, 24V/0.5 A, 12V/0.5 A
RC Conductor Cross Section (max)		16 AWG (Solid) / 1.5 mm ² (Solid)

Order Information

Order Code	300
ProTec 60 T2-xxx-3+0	515 933
ProTec 60 T2-xxx-3+0-R (with remote contacts)	515 942
ProTec T2-xxx-P (plug)	59.C346

*IP 40 (in combination with cover)

ProTec 60 T2 3+0

Internal Configuration

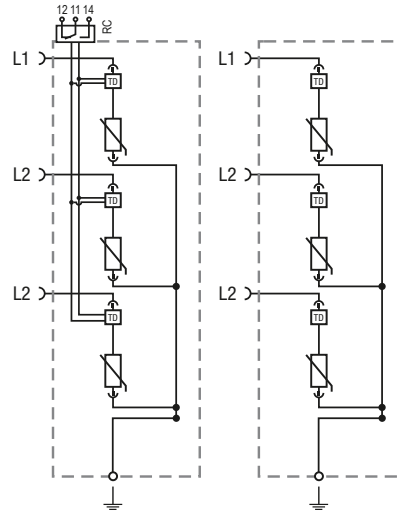

Legend

- L Line Busbar Terminal
- ⊥ PEN Conductor Terminal
- RC Remote Contacts Terminal (Optional)
- TD Thermal Disconnect

Complete Unit

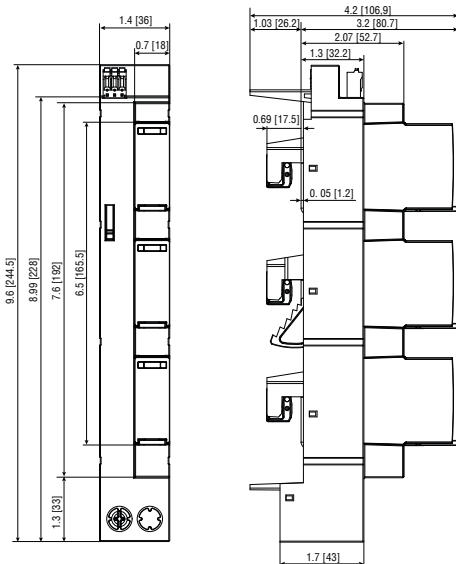

Complete Unit Dimensions & Packaging

ProTec 60 T2-xxx-3+0		300
Weight	pounds [grams]	.955 [433]
Packaging Dimensions (HxWxL)		270 × 375 × 395" [10.6 × 14.8 × 15.5]
ProTec 60 T2-xxx-3+0-R		300
Weight	pounds [grams]	.972 [441]
Packaging Dimensions (HxWxL)		270 × 375 × 395" [10.6 × 14.8 × 15.5]
Standard Order Quantity		20 Units

Spare Unit

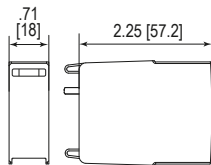

Single Unit

ProTec T2-xxx-P		300
Weight	pounds [grams]	.130 [59]
DIN 43880 Dimension		1 TE / .71 [18]
Packaging Dimensions (HxWxL)		3.2 × 4.5 × 12" [83 × 116 × 305 mm]
Standard Order Quantity		24 Units

inches
[mm]

Information contained in this document is subject to change at any time without notice.

