



ProGRID Series

Surge and Lightning Counters
Surge Protection Device Monitoring











About Raycap

Raycap was founded in 1987 with a vision of creating and providing solutions that protect the world's infrastructure. From telecommunications to new and traditional energy networks, and from transportation systems to industrial applications of all types, Raycap is there with solutions to ensure equipment uptime in spite of harsh electrical environments. The company strives to keep its customers' sophisticated, mission-critical equipment running seamlessly and continuously, and is driven to make ongoing advancements in its surge protection technologies and product offerings.



Table of Contents

Product	Picture	About	Page
Surge and Lightning Counters			
ProSEC II+		<ul style="list-style-type: none"> Main or Sub-distribution board Installed on SPD ground conductor 	6
ProLEC Basic		<ul style="list-style-type: none"> Senses and logs lightning discharges flowing through the down-conductor Installed directly on down-conductor 	7
Surge Protection Device Monitoring			
ProSLS		<ul style="list-style-type: none"> Monitors leakage current of an SPD Snap-on leakage current sensor for SPD line conductors 	10
ProAlarm II		<ul style="list-style-type: none"> Audio and visual SPD failure indication Easy installation on 35 mm DIN Rail 	11
ProSCT		<ul style="list-style-type: none"> Tests the components commonly used in surge protective devices Auto-detects type of component connected 	12
ProSCT SPD Adapter		<ul style="list-style-type: none"> Used to interface a DIN rail base assembly to the ProSCT instrument 	13
Wind Turbine Lightning Strike Monitoring			
ProLEC FO Series		<ul style="list-style-type: none"> Senses a direct lightning strike to a wind turbine 	16



Surge and Lightning Counters

Electrical surges are high frequency current events that present potential danger to sophisticated electronic devices. Electrical surges can occur at almost any time, and the most common causes are lightning strikes, the switching of inductive loads, power grid disturbances, general fault or arcing conditions. In the case of a direct lightning strike the damage caused by surge current is clearly felt and often visible, however many other electrical surge events can go unnoticed. The consequences of such 'quiet' disturbances can be just as detrimental to the operation.

Surge currents can cause loss of data transmission, switch tripping, disturbance of machine control systems and a slow degradation of circuit elements. In addition, a surge can be an indicator of a short circuit which causes currents of power to travel along unintended paths with little or no electrical impedance, for example after a blackout or wiring insulation damage.

Raycap's ProGRID surge and lightning counter solutions have different capabilities that can sense, record and transmit the occurrence of otherwise undetectable surge currents, enabling users to take preventive measures and plan appropriate maintenance.



ProSEC II+



ProLEC Basic

ProSEC II+



Features

- LCD screen displays number of surges, hour, minute and date of surge event
- Buttons for TIME/DATE setting and log viewing
- Replaceable battery, lifetime up to two years
- Easy to install, snap-on surge current sensor
- Complies with: EN/IEC 61000-6-2, EN/IEC 61000-6-4
- EN/IEC CATEGORY: Type I, Type II

Typical Installation

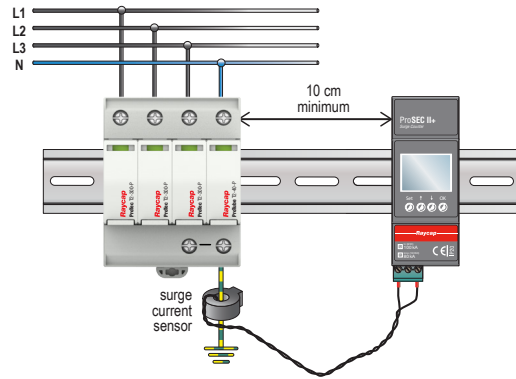

The ProSEC II+ is a surge counter with additional functionality. Besides counting the number of surges, it also logs the hour and date of each surge counted. This additional time and date logging function makes it possible to pinpoint the exact time of every surge and correlate it with equipment and power supply problems inside of a facility or structure.

Technical Data

inches [mm]

Electrical	
ProSEC II+ Order Code	130 100
Nominal Discharge Current (8/20) [I_n]	100 kA
Minimal Discharge Current (8/20) [I_{min}]	100 kA
Maximal Discharge Current (8/20) [I_{max}]	100 kA
Impulse Discharge Current (10/350) [I_{imp}]	80 kA
Minimum Impulse Discharge Current (10/350) [$I_{imp min}$]	100 kA
Maximum Impulse Discharge Current (10/350) [$I_{imp max}$]	80 kA
Power Supply	Replaceable CR17335 lithium battery Lifetime up to two years
Maximum Events Logged	999
Mechanical	
Mounting Method EN 60715	35 mm DIN rail
Maximum Wired Diameter through Current Sensor	0.55" [14 mm]
Sensor Cable	19.7" [0.5m]
Temperature Range	-4 °F to +158 °F [-20 °C to +70 °C]
Environmental Ingress Protection (IP) Rating	IP 20
Enclosure Material	Thermoplastic; Extinguishing degree UL 94 V-0
Packaging Dimension (L x W x D)	4.33" x 1.56" x 3.27" [110 x 42 x 83 mm]
Dimensions DIN 43880	2 TE
Weight	.33 lbs [150 g]
Standards Compliance & Certifications	
Standards	EN/IEC 61000-6-2, EN/IEC 61000-6-4
EN/IEC Category	Type I, Type II
Certification	RoHS, CE
Product Diagram	

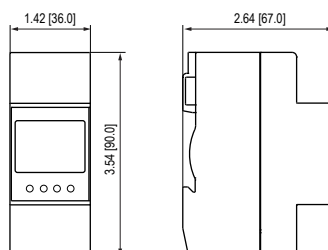

ProLEC Basic



Features

- LCD screen shows the number of lightning strikes, hour, minute and date of lightning events
- Buttons enable TIME/DATE setting and log viewing
- Replaceable battery, lifetime up to four years
- Contact-less sensor is installed easily with no change to existing installation
- Complies with: IEC/EN 62561-6

Typical Installation



ProLEC Basic is a basic lightning current sensor. It senses and logs lightning discharges flowing through the down-conductor. The ProLEC Basic is capable of measuring and withstanding currents up to 100kA (10/350µs).

Installation of the ProLEC Basic on the exterior of a building or structure gives users vital information on the frequency, date, time and atmospheric discharges that affect the structure, enabling repairs or preventative measures.

Technical Data

inches [mm]

Electrical	
ProLEC Basic Order Code	130 523
Threshold Current (10/350µs) [I_{TC}]	1 kA
Maximum Withstand Current (10/350µs) [I_{MCW}]	100 kA
Power Supply	2 Replaceable CR17335 lithium batteries Lifetime up to four years
Maximum Events Logged	999
Mechanical	
Mounting Method	Direct on down-conductor
Temperature Range	-4 °F to +140 °F [-20 °C to +60 °C]
Enclosure Material	Polycarbonate: UL 94 V-Z
Environmental Ingress Protection (IP) Rating	IP 65
Packaging Dimension (L x W x D)	6.5" x 3.4" x 4.13" [165 x 87 x 105 mm]
Weight	.97 lbs [440g]
Standards Compliance & Certifications	
Standards	IEC 62561-6
Certification	RoHS, CE
Product Diagram	

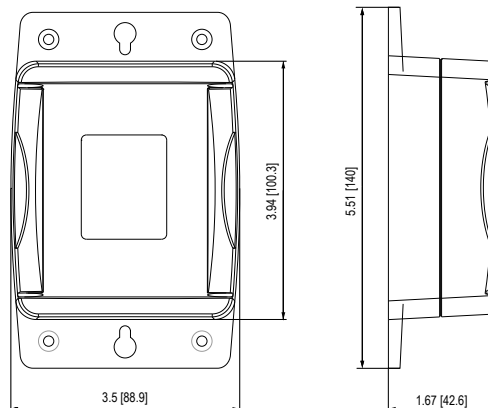

Notes

Surge Protection Device Monitoring

Most Surge Protective Devices (SPDs) are designed to be self-sacrificial, often failing in order to protect more expensive equipment downstream. In essence, their life is based on the magnitude and frequency of surges they have diverted and absorbed. This means that at some point in time they will reach their end-of-life. This will be due to many small surges, or one large surge which exceeds the specified rating of the SPDs maximum discharge or impulse current. Upon reaching end-of-life, a correctly designed SPD will safely disconnect itself from the power supply. Such disconnection usually goes unnoticed since the indicator light is located directly on the SPD, which may not be frequently inspected due to remote location.

With Raycap's SPD life status indication devices it is easy for users to receive information about a failed SPD device immediately, or more importantly, to get a warning when a SPD is nearing its end-of-life. With these devices installed, power supply network operators know when to replace their SPD protection, which is just as important as having surge protection installed in the first place.



ProSLS



ProAlarm II



ProSCT

ProSLS



Features

- Automatic adjustment to all SPD sizes and models
- Replaceable battery, lifetime up to two years
- Continuously monitors leakage current of an SPD

Typical Installation

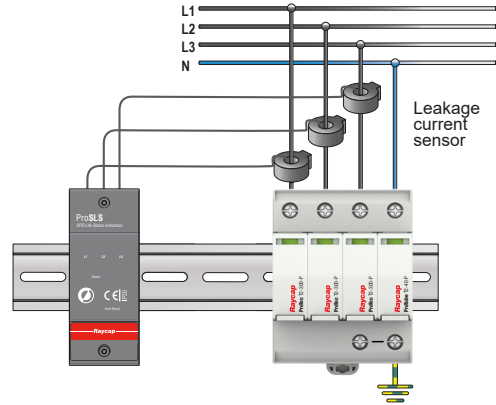

inches [mm]

ProSLS is a device that continuously monitors the leakage current of an SPD, which is the most accurate predictor of a SPD's life status. Using measured current, ProSLS is able to predict the advanced degradation of a SPD and convey this information to the user.

Technical Data

Electrical	
ProSLS Order Code	130 551
Lowest Measurable Current (SPD Leakage)	100 μ A
Power Supply	Replaceable 3.6V(ER AA) battery Lifetime up to two years
Remote Contacts	1 A 45 VAC/30VDC
Mechanical	
Mounting Method EN 60715	35 mm DIN rail
Maximum Wired Diameter through Current Sensor	0.47" [12 mm]
Sensor Cable	39.4" [1 m]
Temperature Range	-22 °F to +158 °F [-30 °C to +70 °C]
Enclosure Material	Thermoplastic; Extinguishing degree UL 94 V-0
Environmental Ingress Protection (IP) Rating	IP 20
Packaging Dimension (L x W x D)	4.33" x 4.53" x 2.95" [110 x 115 x 75 mm]
Dimensions DIN 43880	2 TE
Weight	.88 lbs [440 g]
Standards Compliance & Certifications	
Standards	IEC/EN 61326-1:2021
Certification	RoHS, CE
Product Diagram	

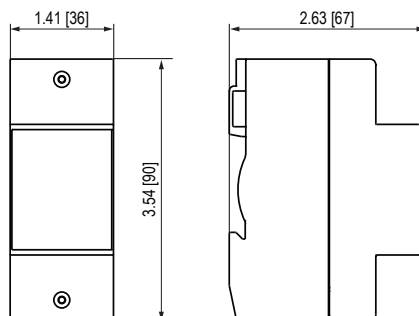

ProAlarm II



Features

- Audio alarm SPD failure indication
- Red LED visual SPD failure indication
- Button for acknowledging and silencing the alarm
- Multiple SPD connected to one ProAlarm II
- Rated voltage AC: 110V-230V

Typical Installation

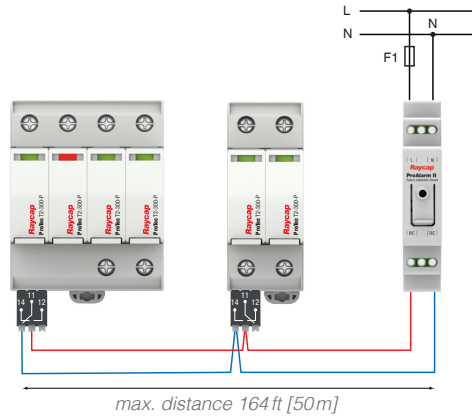

ProAlarm II is a failure indication device that informs a user of the need to replace a failed SPD. It can be quickly and easily installed next to the SPD on the same rail, by making a connection between the RC contacts of the SPD and the alarm unit.

If an SPD fails, the user is informed by a loud audible beeping sound and the illumination of a red LED.

The alarm can be silenced with the press of a button, leaving the LED illuminated until the SPD has been replaced.

Technical Data

inches [mm]

Electrical	
ProAlarm II Order Code	130 562
Rated Voltage (AC)	110 - 230V
Rated Frequency	50Hz - 60Hz
Rated Current	0mA
Rated Current (Beeping)	10mA (110V); 21mA (230V)
Overcurrent Protection (max)	16A
RC Rated Current	10mA (110V); 21mA (230V)
TOV Withstand 120min ⁽¹⁾	442V
Maximum Discharge Current [I_{max}] (8/20 μ s) ⁽¹⁾⁽²⁾	50kA
Impulse Discharge Current [I_{imp}] (10/350 μ s) ⁽¹⁾⁽³⁾	12.5kA
Mechanical	
Overtoltage Category	III
Mounting Method EN 60715	35mm DIN Rail
Operating Temperature	-20 °C to +70 °C [-4 °F to +158 °F]
Enclosure Material	Thermoplastic; Extinguishing Degree UL 94 V-0
Environmental Ingress Protection (IP) Rating	IP 20
Operating State / Display	Red LED / Audible Alarm
Sound Power Level [L_{WA}]	70dB
Dimensions DIN 43880	1TE
Packaging Dimension (L x W x D)	3.1" x 0.9" x 4.3" [77.8 x 23 x 108 mm]
Weight	.12 lbs [53g]
Standards Compliance & Certifications	
Standards	IEC 61010-1:2010+A1:2016, EN 61010-1:2010+A1:2019
Certification	RoHS, CE

⁽¹⁾per IEC/EN 61643-11 ⁽²⁾Only in parallel with T2 SPD where $U_c \leq 350V$. ⁽³⁾Only in parallel with T1 SPD where $U_c \leq 350V$.

Product Diagram

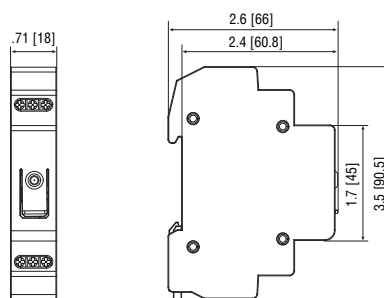

ProSCT (with SPD Adapter)



Features

- Measurement of MOVs, GDTs and TVSs
- Test GDTs and MOVs up to 1500VDC
- Auto-detects type of component connected
- Displays list of successive measurements using LOG Mode
- Color TFT display and touch screen interface
- Rechargeable battery included

Typical Installation

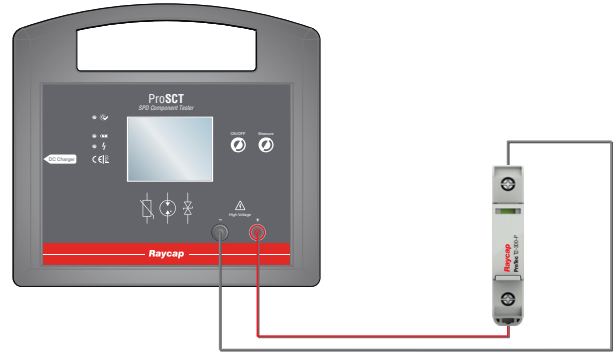

The ProSCT (SPD Component Tester) tests the components commonly used in surge protective devices, such as Gas Discharge Tubes (GDT), Metal Oxide Varistors (MOV), and Transient Voltage Suppressors (TVS).

It is a portable, battery operated instrument with an integrated battery charger housed in a robust enclosure. The instrument features a 320 x 240 pixel TFT color display with touch screen interface.

Technical Data

inches [mm]

Electrical	
ProSCT Order Code	130 574
ProSCT in Suitcase	130 576
ProSCT in Suitcase with SPD Adapter Order Code	130 572
MOV & ABD Test Current	0.1 mA; 0.5 mA; 1 mA
GDT Voltage Ramp	100V/s; 1000V/s
Maximum Test Voltage	1500VDC
MOV Measurement Error	1.5% +/- 2 digit counts
GDT Measurement Error	3.5% +/- 2 digit counts (1 kV/s) 1.6% +/- 2 digit counts (100V/s)
Mechanical	
Operating Temperature (°C)	-10 °C to +50 °C
Enclosure Material	UL-94-HB ABS
Environmental Ingress Protection (IP) Rating	IP 20
Packaging Dimension (L x W x D) - Suitcase	4.5" x 10.1" x 14.3" [115 x 256 x 363 mm]
Weight	2.43 lbs [1100g]
Standards Compliance & Certifications	
Standards	EN 61626-1:2021 IEC 61010-1:2010+A1:2019
Certification	RoHS, CE
Product Diagram	

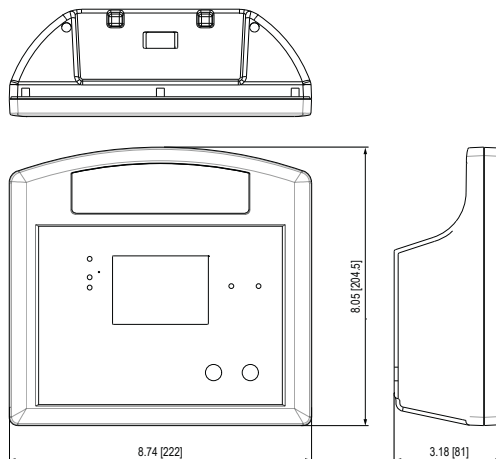

Features

- Connected to the ProSCT instrument via means of cable with banana jack plugs
- 4 connection sockets for different types of SPD modules
- Typical width of SPD modules is 1TE or 2TE (2TE width available only for New SPD spring contacts)

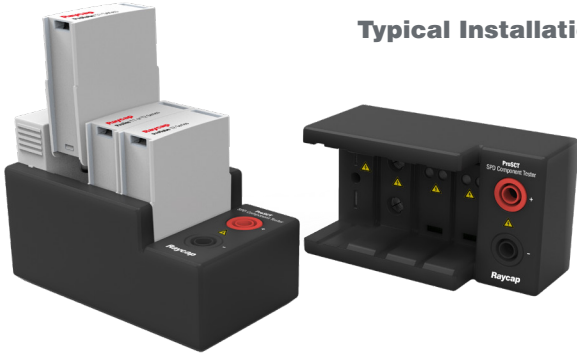

Typical Installation

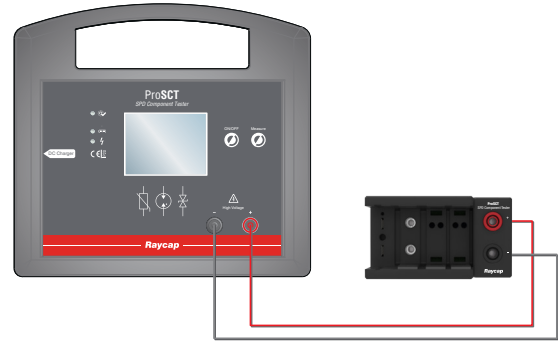

The ProSCT SPD adapter is intended as an accessory for the ProSCT (SPD Component Tester) instrument developed by Raycap. It is used to interface a DIN rail base assembly to the ProSCT instrument. The base assembly is designed to accommodate various generations of Raycap SPD modules.

Technical Data

inches [mm]

Electrical	
SPD Adapter	130 575
Connections towards SPD tester	Banana jack
Connections towards SPD modules	Old SPD flat contacts, NPE bullet contact, 2 New SPD spring contacts (for 1TE and 2TE modules)
Operating temperatures	-10 °C to +50 °C
Packaging Dimension (L×W×D)	4.0"×2.5"×4.3" [102×64×110 mm]
Weight	.38 lbs [175 g]
Standards Compliance & Certifications	
Standards	IEC 61010-1:2010+A1:2019
Certification	RoHS, CE
Connections	

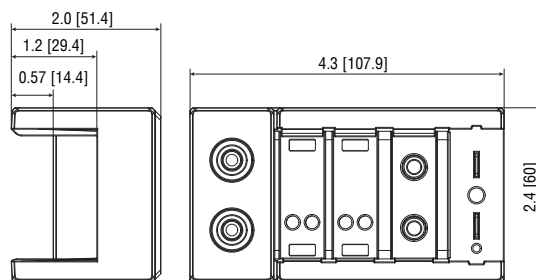



Wind Turbine Lightning Strike Monitoring

The ProLEC FO lightning strike monitoring system helps in the optimization of operations and maintenance procedures at the wind turbine. The system consists of a sensor and optical electrical converter that communicate via fiber optic cable. The optical electrical converter sends data to the external device using a simple signaling protocol.

The user's equipment receives alarms transmitted by the optical electric converter.



ProLEC FO Series

ProLEC FO System



Features

- Senses a direct lightning strike to a wind turbine's Lightning protection system, LPS
- Detects lightning strikes above 2kA amplitude
- Simple mounting
- High voltage isolation

Typical Installation



Technical Data

inches [mm]

Electrical		
ProLEC FO System		130 533
ProLEC FO Sensor		130 535
ProLEC FO		130 534
Threshold Current [I_{TC}]		2 kA
Maximum Withstand Current [I_{mwc}]		100 kA
Threshold Detection Error		+/-200A
Power Supply		Replaceable battery 3.6V (Size D) Battery Life 3 Years typical
Communication		Fiber optic
Mechanical		
Temperature Range	Sensor	-40 °C to +55 °C
Environmental Ingress Protection (IP) Rating		IP 65
Housing Material of Sensor		GD-AI Si 12 (DIN 1725)
Dimensions		156 x 119 x 65 mm [6.15" x 4.7" x 2.6"]
Weight per Unit	Without Battery	1.52 lbs. [690 g]
	With Battery	1.74 lbs. [790 g]
Standards Compliance & Certifications		
Standards		EN/IEC 62561-6:2018, IEC 61326, EN 60068-2
Certification		RoHS, CE

Features

- Isolated fiber optic communications - 10m optic cable
- High voltage isolation

Typical Installation

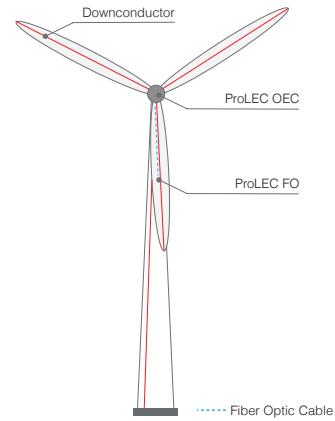

Technical Data

inches [mm]

Electrical			
ProLEC OEC		130 537	
Power Supply		DC 5-30V	
Communication		communication to sensor fiber optic communication to external device see user manual appendix A	
Mechanical			
Temperature Range	Sensor	-40 °C to +55 °C	
Environmental Ingress Protection (IP) Rating		IP 20	
Housing Material of Sensor		PA (polyamide) V0 (UL94)	
Dimensions		124 x 99 x 22.6 mm 4.9" x 3.9" x 0.9"	
Weight per Unit		0.24 lbs. [110 g]	
Standards Compliance & Certifications			
Standards		EN 61326-1	
Certification		RoHS, CE	

Technical Data



Mechanical	
Fiber Optic Cable	130 536
Cable Type	1 mm diameter, Standard POF grade
Attenuation	0.22 dB/m typical (-40°C to 85°C)
Construction	Duplex plastic fiber, with black polyethylene jacket
Flame rating	Comply with UL VW-1 flame retardant specification
Termination	Unterminated
Max. operational length	20m



We reserve the right to introduce changes in performance, dimensions and materials in the course of technical progress. Copyright Raycap all rights reserved. No part of this work, nor of the information laid down herein and/or derivable here from and/or developed in connection with, may be reproduced or used in any form or by any means. Legal action will be taken against infringements. This publication replaces previous editions and the content herein is subject to change at any time without notice.

Raycap Worldwide Locations



Raycap Inc.
806 South Clearwater Loop
Post Falls, ID 83854
United States of America

7555-A Palmetto Commerce Pkwy
North Charleston, SC 29420
United States of America

46 Sellers Street
Kearny, NJ 07032
United States of America

Raycap GmbH
Parking 11
85748 Garching Munich
Germany

Raycap S.A.
Telou & Petroutsou 14
15124 Maroussi Athens
Greece

Raycap S.A. Manufacturing
Industrial Area of Drama
66100 Drama
Greece

Raycap d.o.o.
Poslovna cona Žeje pri Komendi
Pod hrasti 7
1218 Komenda
Slovenia

Raycap Cyprus Ltd.
46 Lefkosias Street
Industrial Area of Dali
2540 Nicosia
Cyprus

Raycap SAS
84 rue Charles Michels
Building B
93200 Saint-Denis
France

Raycap Corporation SRL
102, Barbu Vacarescu,
entrance D, 4th floor D22
020283 Bucharest
Romania

Raycap (Suzhou) Co. Ltd.
Block B, Phase II
of New Sea Union
No. 58 Heshun Road
SIP, Suzhou 215122
Jiangsu Province
China



Raycap

raycap.com • info@raycap.com

©2024 Raycap All rights reserved.
G29-00-333 240423